

## ◎ POWER RATING

Engine Speed rev/min	Type of Operation	Engine Power	
		kWm	Ps
1800	Continuous Power	247	336
	Prime Power	278	378
	Standby Power	298	405
1500	Continuous Power	206	280
	Prime Power	241	328
	Standby Power	272	370

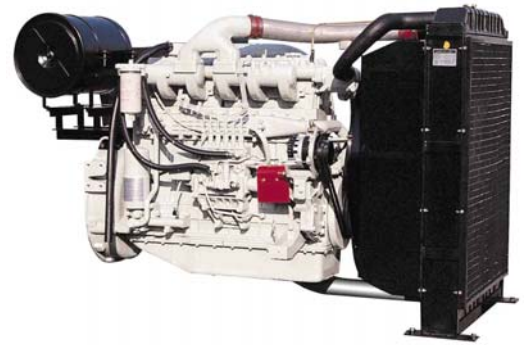

Note : -. The engine performance corresponds to ISO 3046, BS 5514 and DIN 6271.

-. Ratings are based on ISO 8528.

→ **Prime power** available at variable load. The permissible average power out put (during 24h period) shall not exceed 70% of the prime power rating.

→ **Standby power** available in the event of a main power network failure. No overload is permitted.

## ◎ MECHANICAL SYSTEM

○ Engine Model	P126TI
○ Engine Type	In-line 4cycle, water cooled Turbo charged & intercooled (air to air)
○ Combustion type	Direct injection
○ Cylinder Type	Replaceable dry liner
○ Number of cylinders	6
○ Bore x stroke	123(4.84) x 155(6.1) mm(in.)
○ Displacement	11.051(674.5) lit.(in <sup>3</sup> )
○ Compression ratio	17 : 1
○ Firing order	1-5-3-6-2-4
○ Injection timing	16° BTDC
○ Compression pressure	Above 28 kg/cm <sup>2</sup> (398 psi) at 200rpm
○ Dry weight	Approx. 910 kg (2,006 lb)
○ Dimension (LxWxH)	1,383 x 870 x 1,207 mm (54.4 x 34.3 x 47.5 in.)
○ Rotation	Counter clockwise viewed from Flywheel
○ Fly wheel housing	SAE NO.1
○ Fly wheel	Clutch NO.14

## ◎ MECHANISM

○ Type	Over head valve
○ Number of valve	Intake 1, exhaust 1 per cylinder
○ Valve lashes at cold	Intake 0.30mm (0.0118 in.) Exhaust 0.30mm (0.0118 in.)

## ◎ VALVE TIMING

	Opening	Close
○ Intake valve	18 deg. BTDC	34 deg. ABDC
○ Exhaust valve	46 deg. BBDC	14 deg. ATDC

## ◎ FUEL CONSUMPTION

○ Prime Power (lit/hr)	1,500 rpm	1,800 rpm
25%	16.4	20.3
50%	30.0	36.2
75%	43.6	52.3
100%	58.1	70.3
○ Standby Power (lit/h)	1,500 rpm	1,800 rpm
25%	18.3	21.5
50%	33.4	38.7
75%	49.1	56.3
100%	66.2	76.5

## ◎ FUEL SYSTEM

○ Injection pump	Zexel in-line "P" type
○ Governor	Electric type
○ Feed pump	Mechanical type
○ Injection nozzle	Multi hole type
○ Opening pressure	220 kg/cm <sup>2</sup> (3,129 psi)
○ Fuel filter	Full flow, cartridge type
○ Used fuel	Diesel fuel oil

## ◎ LUBRICATION SYSTEM

○ Lub. Method	Fully forced pressure feed type
○ Oil pump	Gear type driven by crankshaft
○ Oil filter	Full flow, cartridge type
○ Oil pan capacity	High level 23 liters ( 6.1 gal.) Low level 20 liters ( 5.3 gal.)
○ Angularity limit	Front down 25 deg. Front up 25 deg. Side to side 15 deg.
○ Lub. Oil	Refer to Operation Manual

# P126TI G-DRIVE

### ◎ COOLING SYSTEM

- Cooling method      Fresh water forced circulation
- Water capacity      19 liters ( 5.02 gal.)  
(engine only)
- Pressure system      Max. 0.9 kg/cm<sup>2</sup> ( 12.8 psi)
- Water pump            Centrifugal type driven by gear
- Water pump Capacity 320 liters ( 84.5 gal.)/min  
at 1,800 rpm (engine)
- Thermostat           Wax – pellet type  
Opening temp. 71°C  
Full open temp. 85°C
- Cooling fan           Blower type, plastic  
755 mm diameter, 7 blade

### ◎ ELECTRICAL SYSTEM

- Charging generator    24V x 45A alternator
- Voltage regulator      Built-in type IC regulator
- Starting motor          24V x 6.0kW
- Battery Voltage        24V
- Battery Capacity       150 AH (recommended)
- Starting aid (Option)   Block heater

### ◎ ENGINEERING DATA

- |                                 |  |
|---------------------------------|--|
| ○ Water flow                    | 265 liters/min @1,500 rpm                                      |
| ○ Heat rejection to coolant     | 25.5 kcal/sec @1,500 rpm                                       |
| ○ Heat rejection to CAC         | 7.2 kcal/sec @1,500 rpm  |
| ○ Air flow                      | 16.4 m <sup>3</sup> /min @1,500 rpm                            |
| ○ Exhaust gas flow              | 42.9 m <sup>3</sup> /min @1,500 rpm                            |
| ○ Exhaust gas temp.             | 560 °C @1,500 rpm  |
| <hr/>                           |  |
| ○ Water flow                    | 320 liters/min @1,800 rpm                                      |
| ○ Heat rejection to coolant     | 29.0 kcal/sec @1,800 rpm                                       |
| ○ Heat rejection to CAC         | 12.0 kcal/sec @1,800 rpm                                       |
| ○ Air flow                      | 23.0 m <sup>3</sup> /min @1,800 rpm                            |
| ○ Exhaust gas flow              | 58.1 m <sup>3</sup> /min @1,800 rpm                            |
| ○ Exhaust gas temp.             | 510 °C @1,800 rpm  |
| <hr/>                           |  |
| ○ Max. permissible restrictions |  |
| - .Intake system                | 220 mmH <sub>2</sub> O initial<br>635 mmH <sub>2</sub> O final |
| - .Exhaust system               | 600 mmH <sub>2</sub> O max.                                    |

### ◆ CONVERSION TABLE

- |                                    |                                    |
|------------------------------------|------------------------------------|
| in. = mm x 0.0394                  | lb/ft = N.m x 0.737                |
| PS = kW x 1.3596                   | U.S. gal = lit. x 0.264            |
| psi = kg/cm <sup>2</sup> x 14.2233 | kW = 0.2388 kcal/s                 |
| in <sup>3</sup> = lit. x 61.02     | lb/PS.h = g/kW.h x 0.00162         |
| hp = PS x 0.98635                  | cfm = m <sup>3</sup> /min x 35.336 |
| lb = kg x 2.20462                  |                                    |

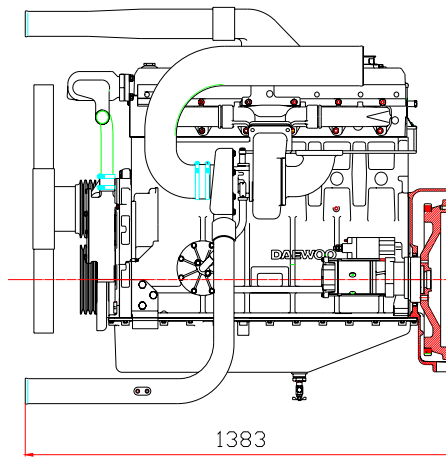
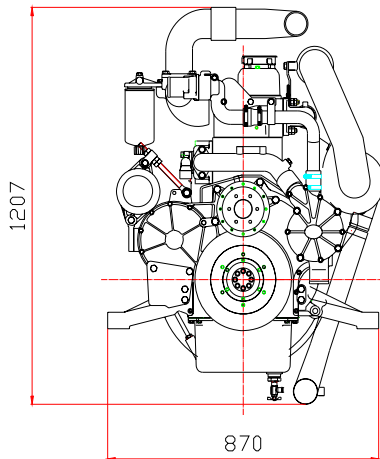

**Head office**  
 7-11, Hwasu-Dong, Dong-Gu, Incheon, Korea  
**TEL : 82-32-760-1437, 1964 FAX : 82-32-760-1964**

**Seoul Office**  
 Doosan Infracore Co. Ltd.,  
 22nd Floor, Doosan Tower, 18-12, Euljiro 6-ga, Jung-gu,  
 Seoul, Korea.  
**TEL : 82-2-3398-8521~8535 FAX : 82-2-3398-8509**  
**Web site : www.doosaninfracore.com**

※ Specifications are subject to change without prior notice